

MRF Timing System

Jukka Pietarinen

Timing Workshop CERN
February 2008

Micro-Research Finland Oy

- Founded in 1985
- Timing System development initiated in 1999 by the design of the timing system for SLS (series 100)
- References:
 - SLS, Paul-Scherrer Institute, Switzerland
 - Diamond Light Source Ltd., U.K.
 - ASP, Australia
 - BEPCII, Institute for High Energy Physics, Beijing, China
 - LCLS, Stanford Linear Accelerator Center, USA
 - SNS, Oak Ridge National Laboratory, USA
 - SSRF, Shanghai, China
 - Elettra, Trieste, Italy
 - ALBA, Spain
 - And others...

Timing System Overview

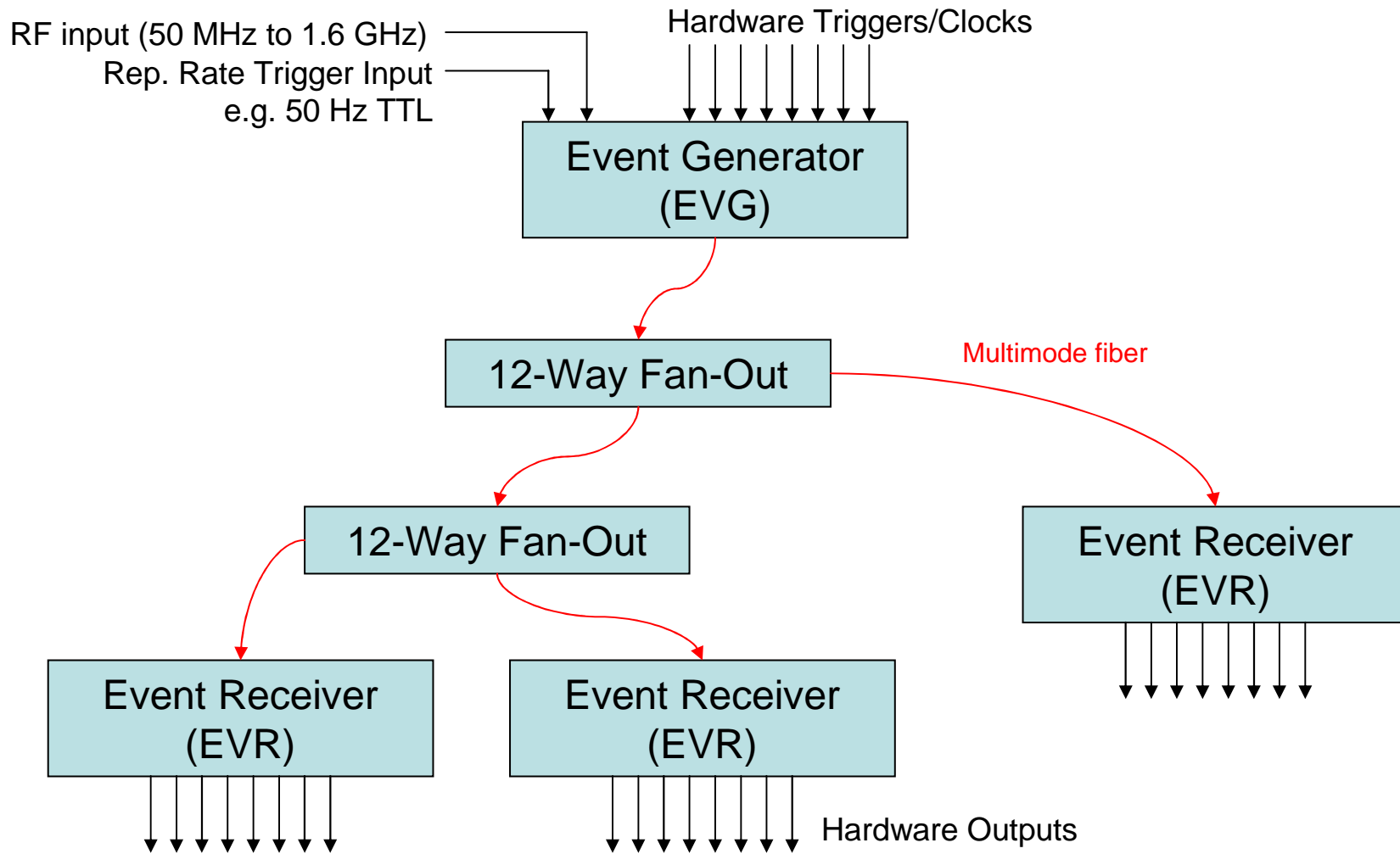

Timing System with Upstream

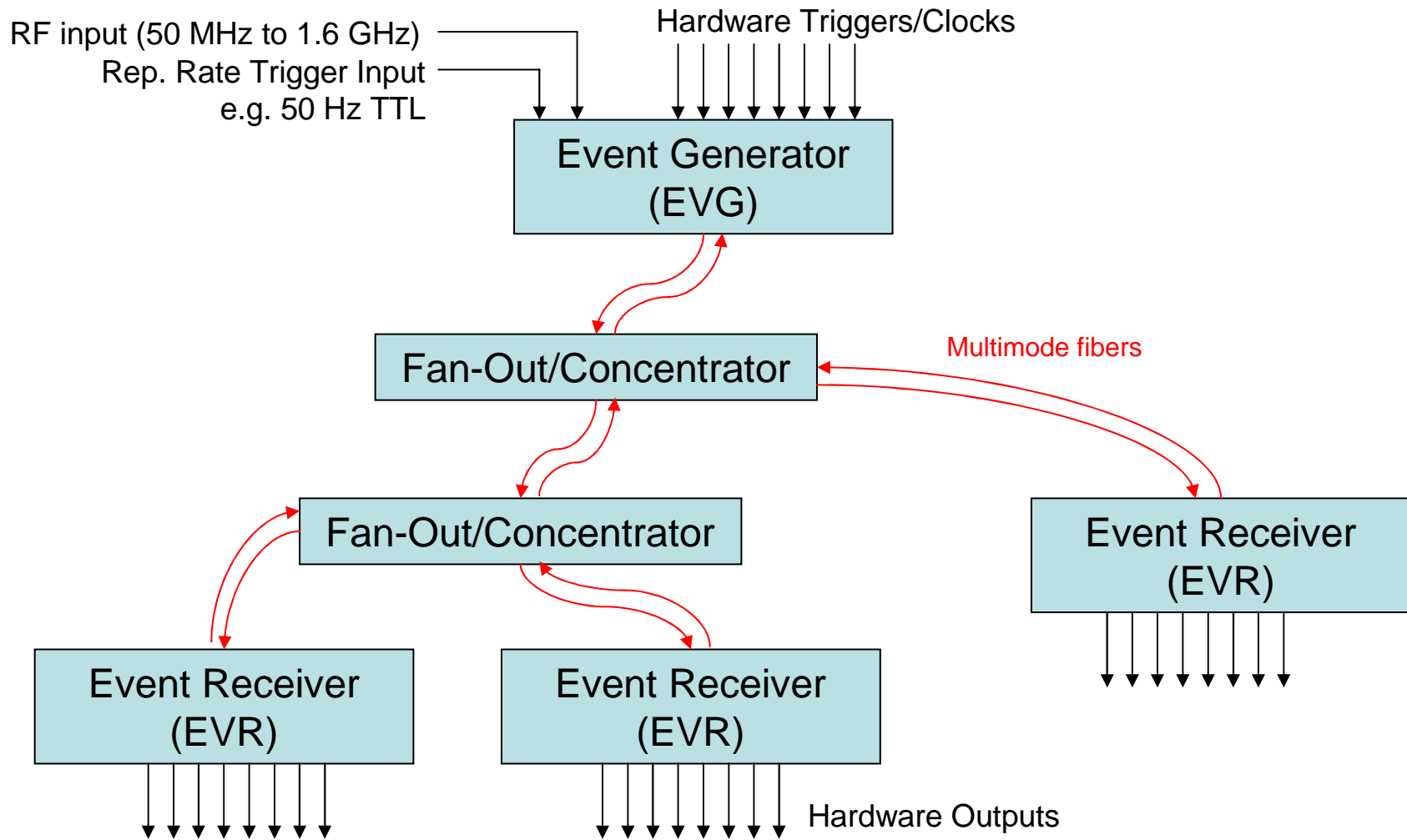

Timing System Features

- Event driven system, 255 event codes
- Events are sent out with the event clock rate which is derived from an external RF reference
- Event clock rate 50 to 125 MHz
- Events generated
 - From external HW inputs
 - Two sequencers (up to 2048 events/sequencer)
 - Multiplexed counters
 - Software
- Eight distributed bus signals, updated simultaneously at the event clock rate, no interference with events
- Event Generators may be cascaded
 - EVGs synchronized to different clocks

Timing System Features (cont.)

- Event Receivers lock to the EVG event clock and generate
 - pulse outputs with programmable delay and width
 - level outputs
 - Software interrupts
 - Synchronous clocks
 - RF recovery (VME-EVR-230RF only)
- Support for Timestamping/distribution of time
- Timestamping of external events
- Data transfer support with predictable timing
 - Up to 2 kbyte buffer
 - Max. 62.5 Mbytes/s
- SFP transceivers, multi-mode fiber

Event Generator (VME-EVG-230)



SFP transceiver
• Optical signal to EVRs (fan-outs)
• Upstream EVG

RF input

- Event clock divided from RF /1, /2, ... , /32
- Event clock 50 – 125 MHz

Line synchronisation input
e.g. 50 Hz / 60 Hz TTL level

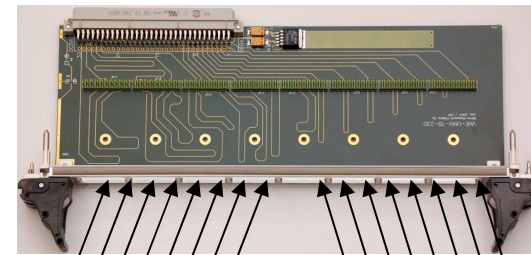

Distributed bus inputs

External trigger inputs

Two Universal I/O slots

- Up to four programmable I/O, TTL/NIM/Optical

Event Generator (cPCI-EVG-220/230)

Two Universal I/O slots

- Up to four programmable I/O, TTL/NIM/Optical

Line synchronisation input
e.g. 50 Hz / 60 Hz TTL level

RF input

- Event clock divided from RF
- /1, /2, ... , /32
- Event clock 50 to 100/125 MHz

SFP transceiver

- Optical signal to EVRs (fan-outs)
- Upstream EVG

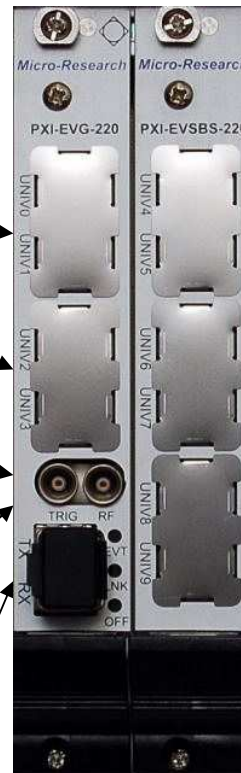

Optional side-by-side I/O extension module for three Universal I/O slots, providing up to six I/O signals



VME Event Receiver (VME-EVR-230)

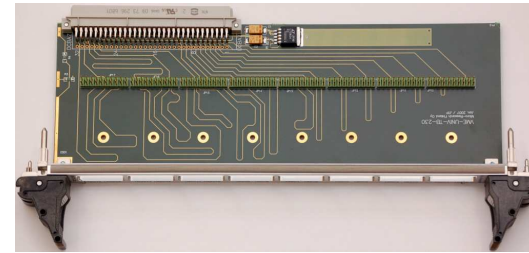

Eight Universal I/O slots
• Up to sixteen programmable I/O, TTL/NIM/Optical

SFP transceiver
• Optical signal from EVG (or fan-out)

Two Universal I/O slots
• Up to four programmable I/O, TTL/NIM/Optical

Programmable outputs
• 8 TTL level
• External trigger input

VME Event Receiver with RF output (VME-EVR-230RF)

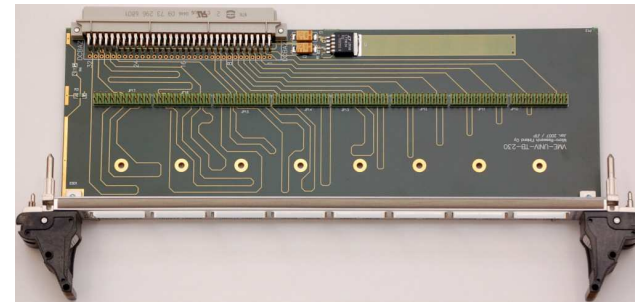
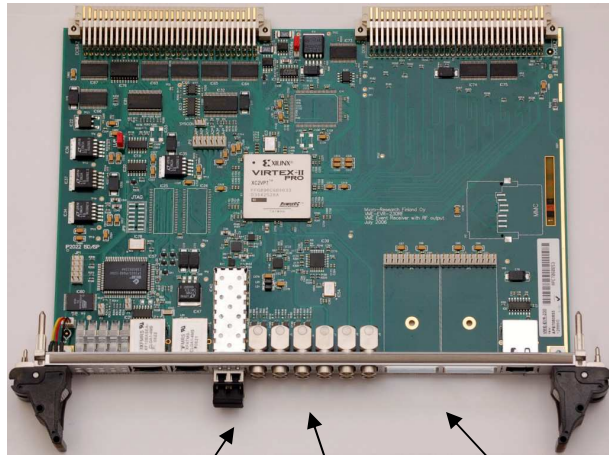

SFP transceiver
• Optical signal from EVG (or fan-out)

Programmable outputs
• 4 TTL level
• External trigger input
• External inhibit input

Two Universal I/O slots
• Up to four programmable I/O, TTL/NIM/Optical

• 3 Differential CML RF/pattern outputs with 1/20th event cycle resolution (400 ps @ 8 ns event clock cycle)

CompactPCI Event Receiver (cPCI-EVR-220/230)

Two Universal I/O slots

- Up to four programmable I/O, TTL/NIM/Optical

- External trigger input
- External inhibit input

- SFP transceiver
- Optical signal from EVG (or fan-out)



Optional side-by-side I/O extension module for three Universal I/O slots, providing up to six I/O TTL/NIM/Optical

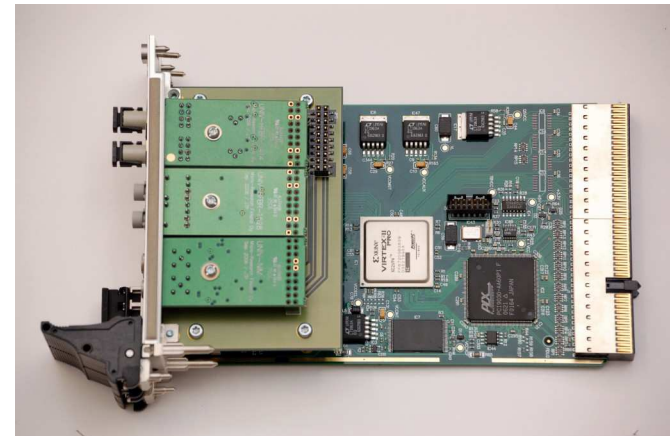

PMC Event Receiver (PMC-EVR-230)



- SFP Transceiver
- External trigger input
- Three TTL outputs

Transition Board I/O through VME P2

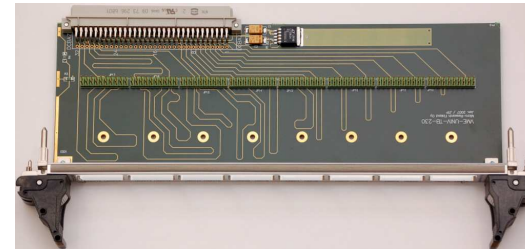

- Eight Universal I/O slots
- Up to sixteen programmable I/O, TTL/NIM/Optical

Event Receiver Performance

Module	Resolution	Jitter typ.
VME-EVR-230	8 ns min. *)	< 25 ps RMS
VME-EVR-230RF (standard outputs)	8 ns min. *)	< 15 ps RMS
VME-EVR-230RF (CML outputs)	400 ps (8 ns / 20)	< 5 ps RMS
cPCI-EVR-220	10 ns min.	< 25 ps RMS
cPCI-EVR-230 PMC-EVR-230	8 ns min. *)	< 25 ps RMS

*) 10 ps with UNIV-LVPECL-DLY module

Universal I/O Modules

- 25.4 mm x 52 plug-in units
- two outputs or inputs each
- can be fitted on VME-EVG-230 and VME-EVR-230(RF), VME-UNIV-TB, CompactPCI EVG/EVR, CompactPCI side-by-side module
- Module specification available on-line for custom module development

Optical
HFBR-1414



820 nm

Optical
HFBR-1528



650 nm
1 mm POF

NIM
Output

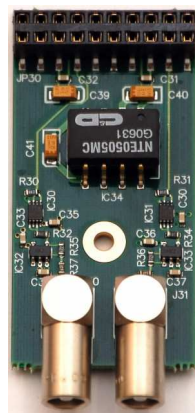

TTL
Output



TTL
Input



LVPECL
Output



LVPECL
Output



10 ps step
Delay
tuning

Fan-Out Modules (VME/cPCI-FOUT-12)

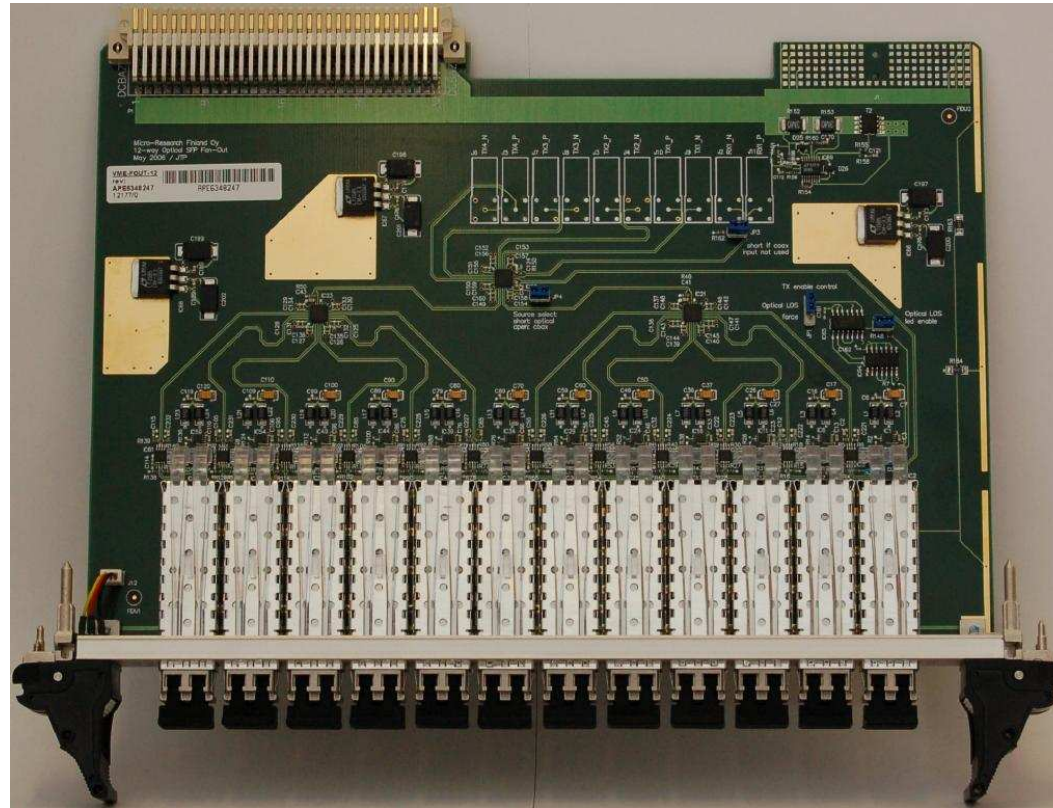

Fan-Out Concentrator Module (cPCI-FOUT-CT-8)

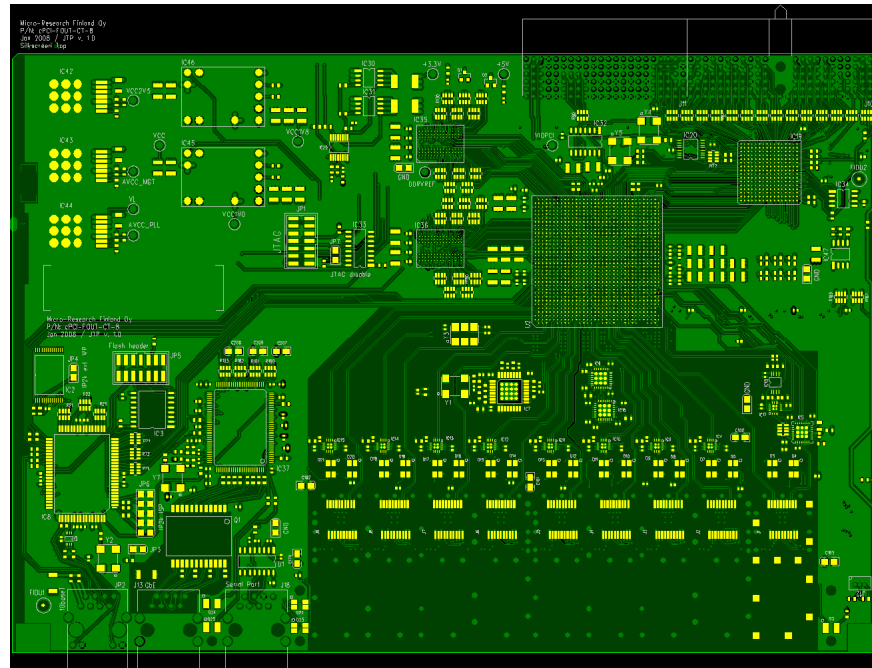

- Upstream events
- Upstream distributed bus
- Upstream data transfer
- Fiber length measurement

Fiber Delay Measurement Setup

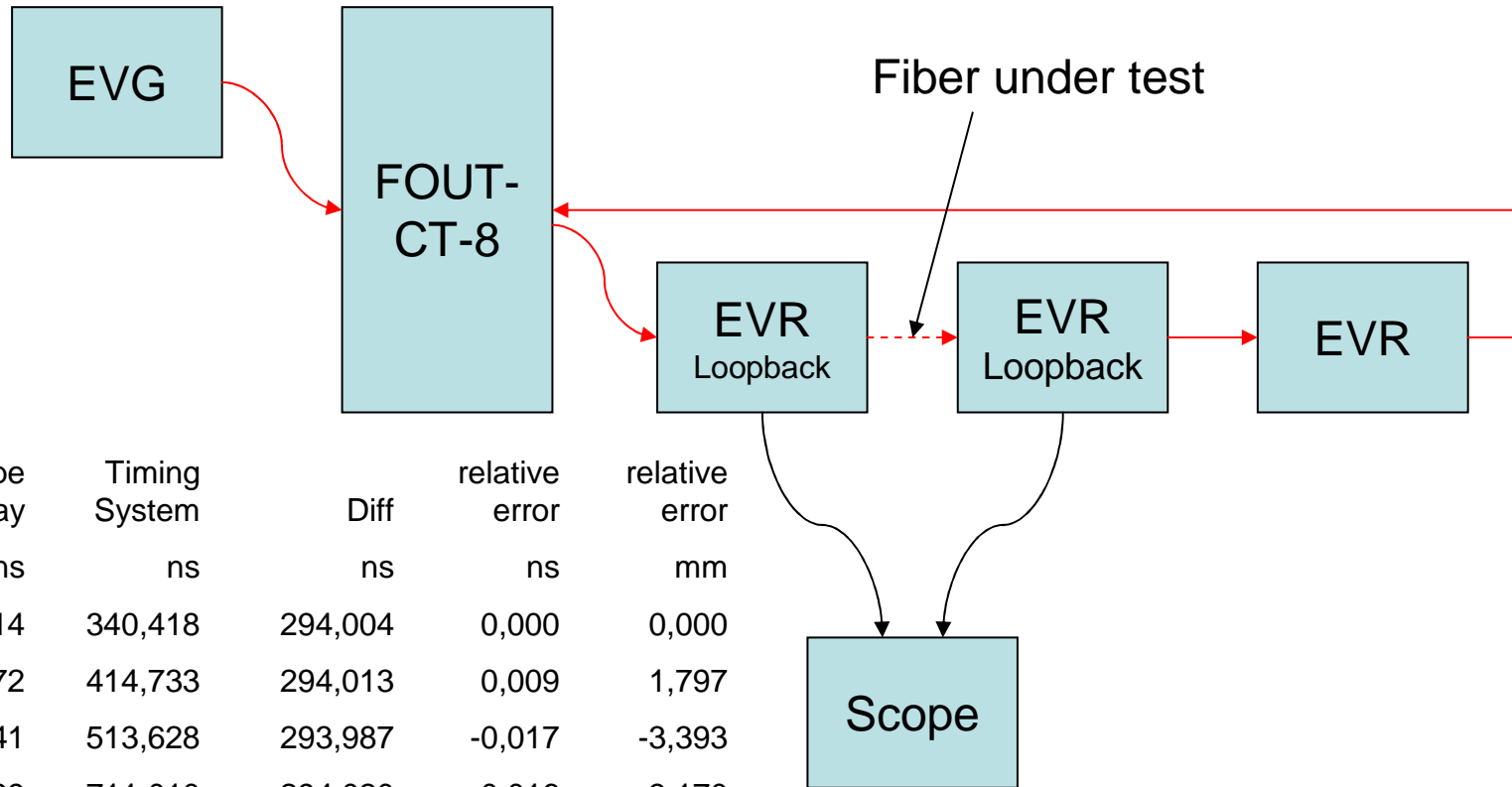

Fiber length	Scope Delay	Timing System	Diff	relative error	relative error
m	ns	ns	ns	ns	mm
9	46,414	340,418	294,004	0,000	0,000
24	120,72	414,733	294,013	0,009	1,797
44	219,641	513,628	293,987	-0,017	-3,393
84	416,99	711,010	294,020	0,016	3,170
164	812,625	1106,629	294,004	-0,001	-0,105
294	1455,446	1749,457	294,011	0,007	1,340
554	2741,692	3035,692	294,000	-0,005	-0,930

Fiber Delay Measurement

1 km Fiber

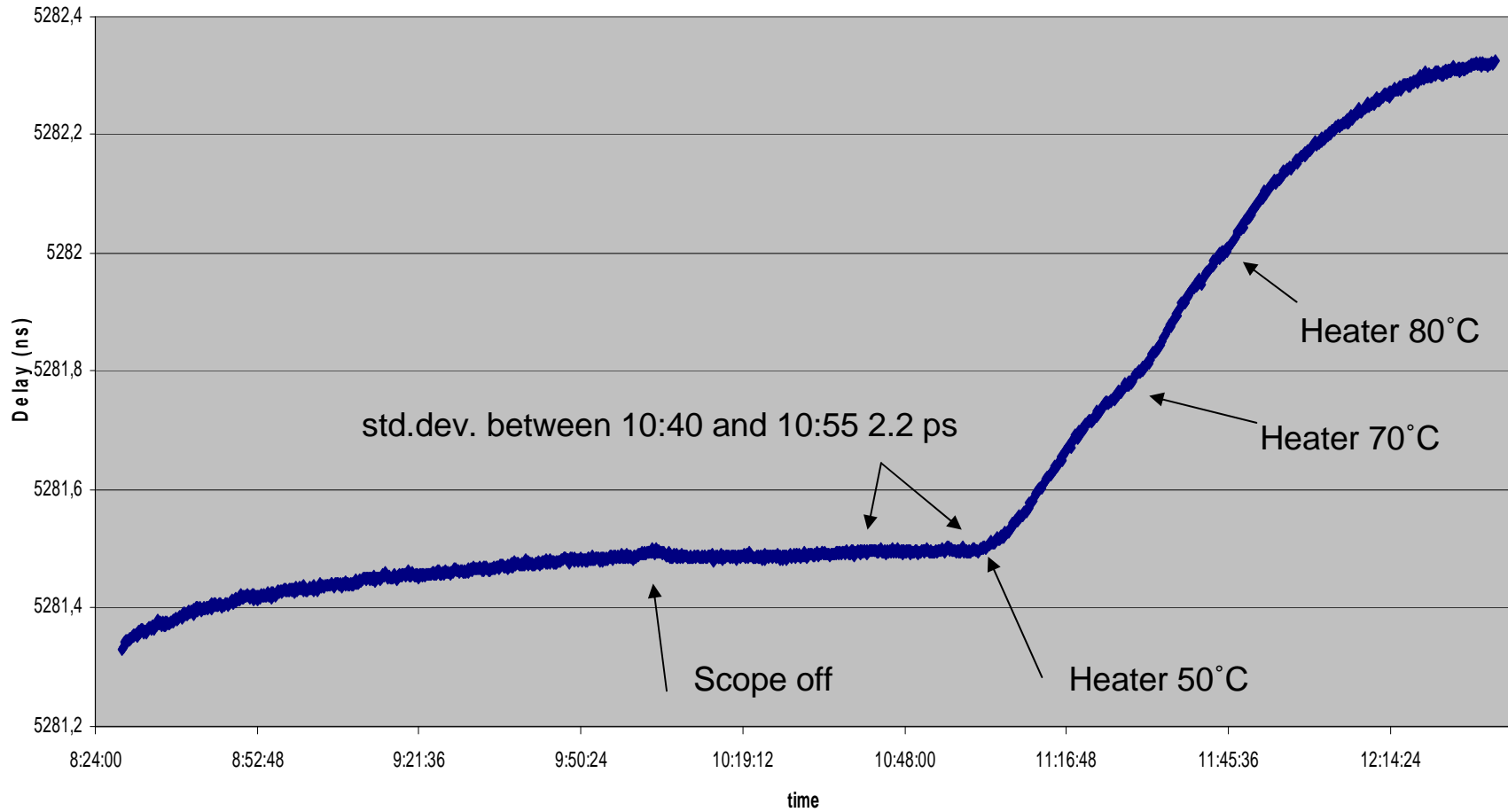

Fiber Delay Measurement

730 m Fibre

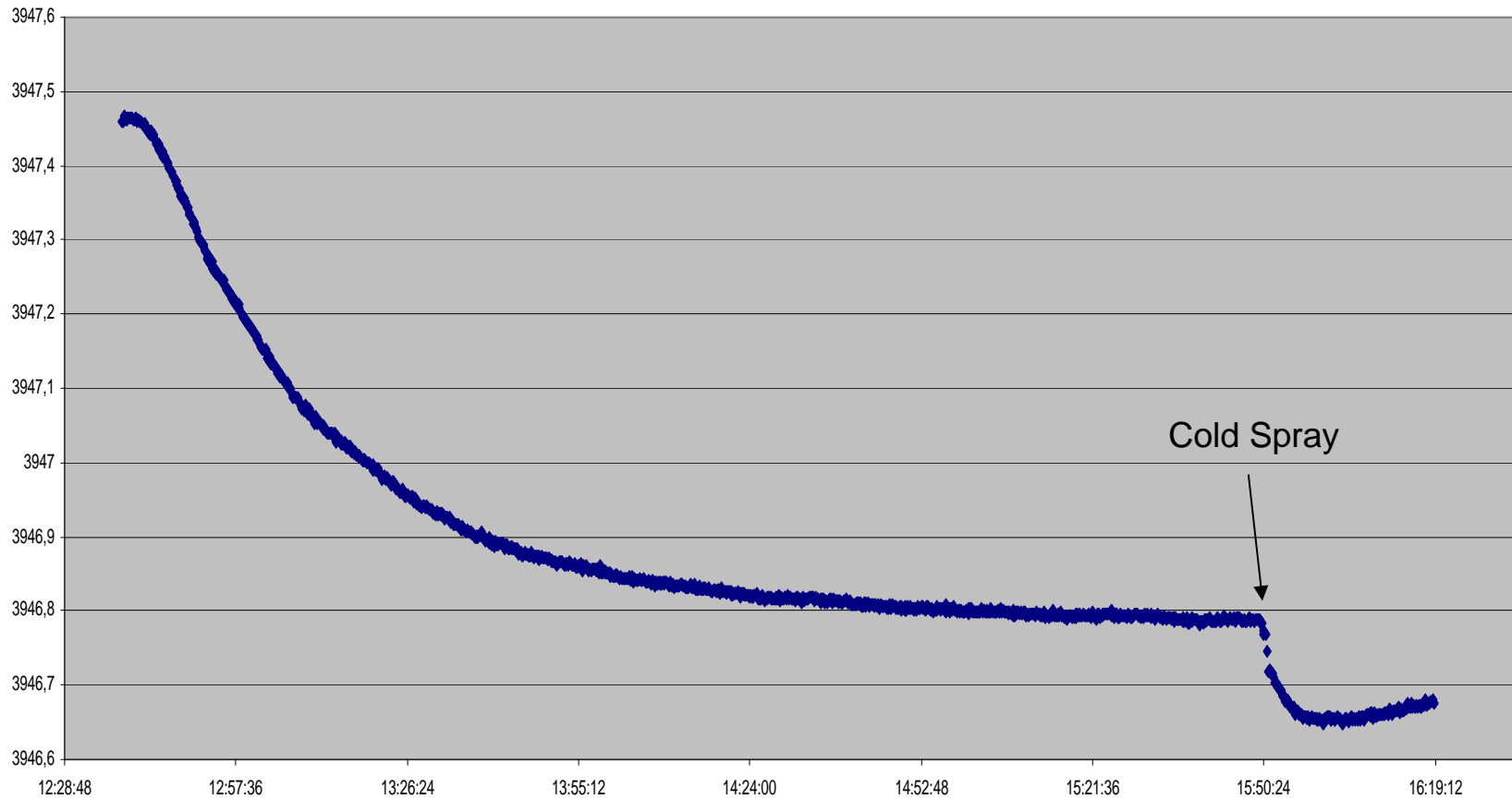

VME-ADC-200 4 x 1 Gsps ADC Prototype



- Designed to be used for filling pattern feedback at SLS
- Two Atmel AT84AD001B Dual 8-bit 1 Gsps ADCs
 - 2 Gsps in interleaved mode
 - 500 mVpp Differential Analog Input
 - 1.5 GHz Full Power Input Bandwidth (-3 dB)
 - Sample clock can be shifted in 10 ps steps
- Integrated Event Receiver
 - Production version will recover RF (ADC conversion clock) from event system
 - Timing/triggering from event system

SLS filling pattern sample with VME-ADC-200 prototype

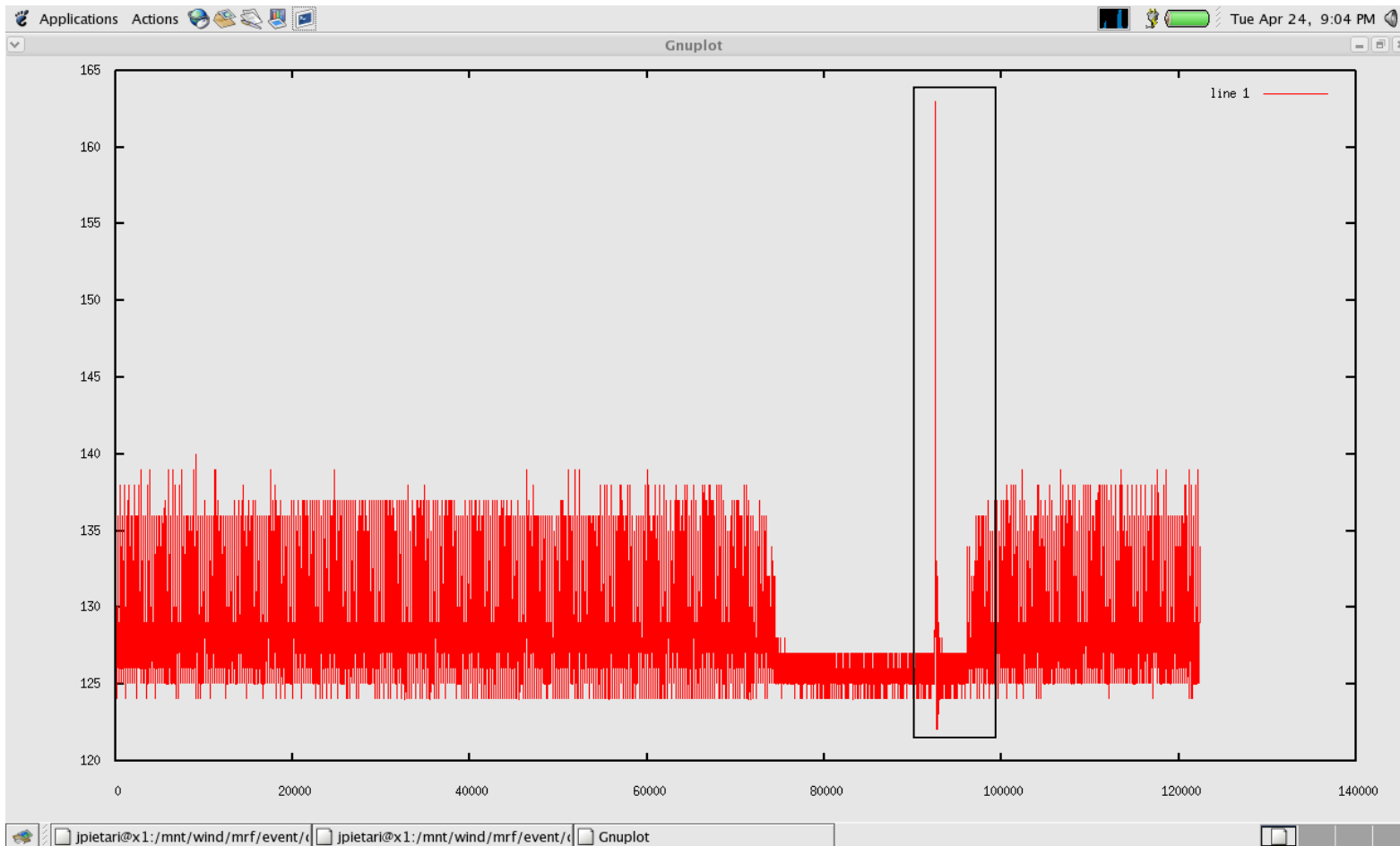

SLS filling pattern sample with VME-ADC-200 prototype

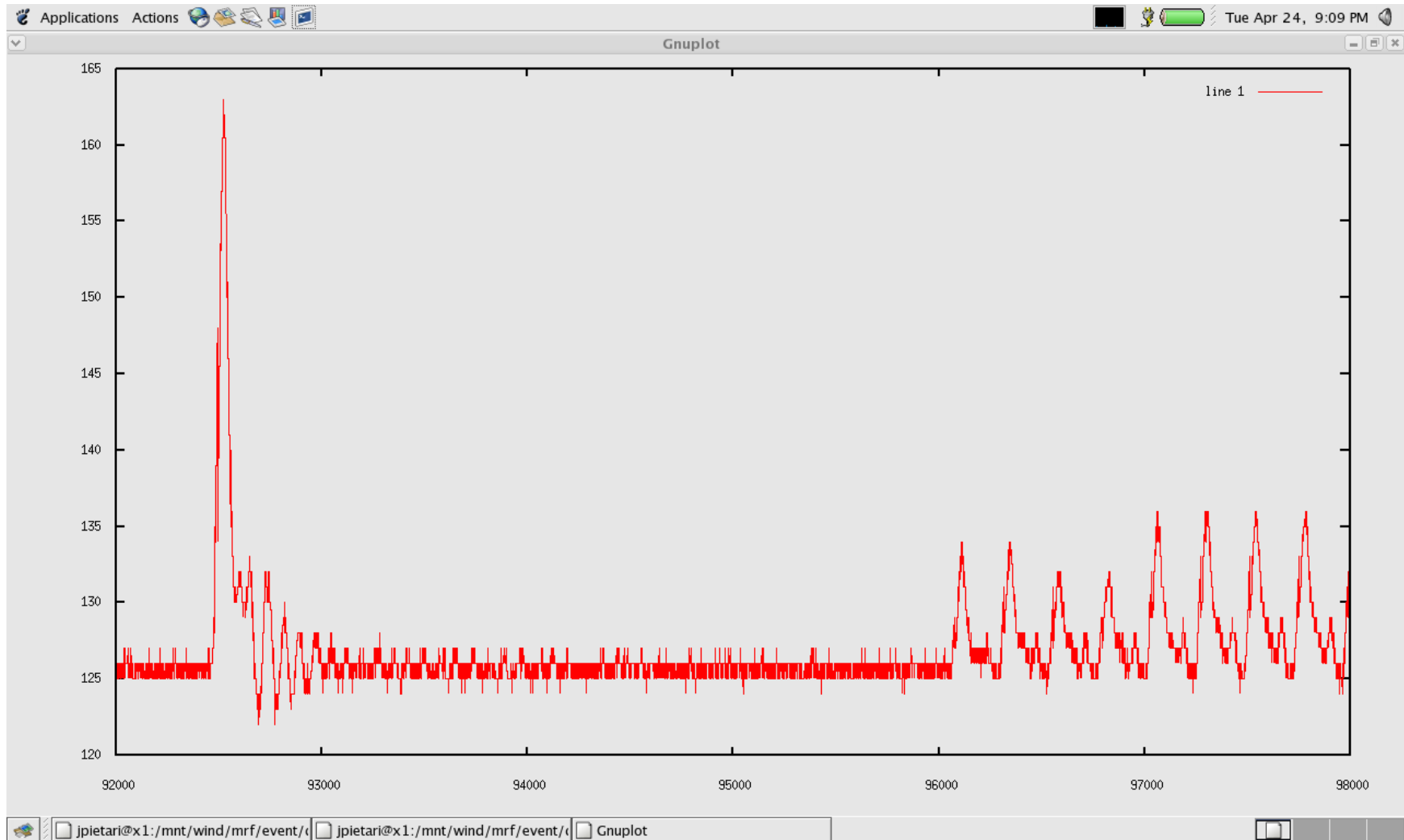

Other products

- Electron Gun Triggering
 - Transmitter module EGUN-TX
 - Receiver module at high voltage EGUN-RX

Future Interests

- EPIC form factor EVR prototype (see <http://www.pc104.org>)
 - Integrated CPU (either soft-CPU inside FPGA or Freescale Coldfire)
 - Integrated EVR
 - PC104 bus / PCI bus
- Event Receiver for CompactRIO (National Instruments)
 - Feasibility? cRIO interface not very suitable for timing receiver